

EMC TEST REPORT For

Dongguan kaideng Energy Technology Co., Ltd.

Micro Inverter

Model No.: WVC-295, WVC-300, WVC-350, WVC-600, WVC-700, WVC-1200,
WVC-1400, WVC-2000, WVC-2400, WVC-2800

Prepared for : DONGGUAN KAIKENG ENERGY TECHNOLOGY CO.,
LTD.

Address : 4 th floor, Fuyuan business building, no. 1, Lane 13,
xin'an maiyuan Road, Chang 'an town, Dongguan City

Prepared by : Shenzhen RCT testing technonlgy Co.,Ltd
Address : 1417, Junlan building, Guanlan District, Longhua,
Shenzhen,Guangdong, China

Tel: (0755) 21038450

Fax: (0755) 21038451

Report No. : RCT20200824002EMC

Date of Test : Aug 02, 2020 to Aug 23, 2020

Date of Report : Aug 24, 2020

TABLE OF CONTENT

TEST REPORT DESCRIPTION	PAGE
1. SUMMARY OF TEST RESULT	7
2. GENERAL INFORMATION	8
2.1. Description of Device (EUT).....	8
2.2. Description of Support Device.....	8
2.3. Description of Test Facility.....	8
2.4. Measurement Uncertainty.....	9
3. MEASURING DEVICE AND TEST EQUIPMENT	10
3.1. For Power Line Conducted Emission.....	10
3.2. For Radiated Emission Measurement.....	10
3.3. For Harmonic Current / Flicker Measurement.....	10
3.4. For Electrostatic Discharge Immunity Test.....	10
3.5. For RF Strength Susceptibility Test.....	11
3.6. For Electrical Fast Transient /Burst Immunity Test.....	11
3.7. For Surge Immunity Test.....	11
3.8. For Injected Current Susceptibility Test.....	11
3.9. For Magnetic Field Immunity Test.....	12
3.10. For Voltage Dips and Interruptions Test.....	12
4. POWER LINE CONDUCTED EMISSION MEASUREMENT	13
4.1. Block Diagram of Test Setup.....	13
4.2. Measuring Standard.....	13
4.3. Power Line Conducted Emission Limits.....	13
4.4. EUT Configuration on Measurement.....	13
4.5. Operating Condition of EUT.....	13
4.6. Test Procedure.....	14
4.7. Measuring Results.....	14
5. RADIATED EMISSION MEASUREMENT	17
5.1. Block Diagram of Test.....	17
5.2. Measuring Standard.....	17
5.3. Radiated Emission Limits.....	17
5.4. EUT Configuration on Measurement.....	18
5.5. Operating Condition of EUT.....	18
5.6. Test Procedure.....	18
5.7. Measuring Results.....	18
6. HARMONIC CURRENT EMISSION MEASUREMENT	23
6.1. Block Diagram of Test Setup.....	23
6.2. Measuring Standard.....	23
6.3. Operation Condition of EUT.....	23
6.4. Measuring Results.....	23
7. VOLTAGE FLUCTUATION AND FLICKER MEASUREMENT	27
7.1. Block Diagram of Test Setup.....	27
7.2. Measuring Standard.....	27
7.3. Operation Condition of EUT.....	27
7.4. Measuring Results.....	27
8. IMMUNITY PERFORMANCE CRITERIA DESCRIPTION	29
9. ELECTROSTATIC DISCHARGE IMMUNITY TEST	30

9.1.	Block Diagram of Test Setup.....	30
9.2.	Test Standard.....	30
9.3.	Severity Levels and Performance Criterion.....	30
9.4.	EUT Configuration.....	31
9.5.	Operating Condition of EUT.....	31
9.6.	Test Procedure.....	31
9.7.	Test Results.....	31
10.	RF FIELD STRENGTH SUSCEPTIBILITY TEST	33
10.1.	Block Diagram of Test.....	33
10.2.	Test Standard.....	33
10.3.	Severity Levels and Performance Criterion.....	34
10.4.	EUT Configuration on Test.....	34
10.5.	Operating Condition of EUT.....	34
10.6.	Test Procedure.....	34
10.7.	Test Results.....	34
11.	ELECTRICAL FAST TRANSIENT/BURST IMMUNITY TEST.....	38
11.1.	Block Diagram of Test Setup.....	38
11.2.	Test Standard.....	38
11.3.	Severity Levels and Performance Criterion.....	38
11.4.	EUT Configuration.....	38
11.5.	Operating Condition of EUT.....	39
11.6.	Test Procedure.....	39
11.7.	Test Result.....	39
12.	SURGE IMMUNITY TEST.....	41
12.1.	Block Diagram of Test Setup.....	41
12.2.	Test Standard.....	41
12.3.	Severity Levels and Performance Criterion.....	41
12.4.	EUT Configuration.....	41
12.5.	Operating Condition of EUT.....	42
12.6.	Test Procedure.....	42
12.7.	Test Result.....	42
13.	INJECTED CURRENTS SUSCEPTIBILITY TEST	44
13.1.	Block Diagram of Test Setup.....	44
13.2.	Test Standard.....	44
13.3.	Severity Levels and Performance Criterion.....	44
13.4.	EUT Configuration.....	44
13.5.	Operating Condition of EUT.....	45
13.6.	Test Procedure.....	45
13.7.	Test Results.....	45
14.	MAGNETIC FIELD SUSCEPTIBILITY TEST	47
14.1.	Block Diagram of Test.....	47
14.2.	Test Standard.....	47
14.3.	Severity Levels and Performance Criterion.....	47
14.4.	EUT Configuration on Test.....	48
14.5.	Test Procedure.....	48
14.6.	Test Results.....	48
15.	VOLTAGE DIPS AND INTERRUPTIONS TEST	50
15.1.	Block Diagram of Test Setup.....	50
15.2.	Test Standard.....	50
15.3.	Severity Levels and Performance Criterion.....	50
15.4.	EUT Configuration.....	50

15.5. Operating Condition of EUT.....	51
15.6. Test Procedure.....	51
15.7. Test Result.....	52

APPENDIX (Photos of EUT) (4 Pages)

TEST REPORT DESCRIPTION

Applicant : Dongguan kaideng Energy Technology Co., Ltd.
Manufacturer : Dongguan kaideng Energy Technology Co., Ltd.
Trademark : KD
EUT : Micro Inverter
Model No. : WVC-295, WVC-300, WVC-350, WVC-600, WVC-700, WVC-1200, WVC-1400,
WVC-2000, WVC-2400, WVC-2800
Input Voltage : 80~280Vac

Measurement Procedure Used:

EN 61000-6-3:2007+A1:2011+AC:2012
EN 61000-6-1:2007
(IEC 61000-4-2:2008, IEC 61000-4-3:2006+A1:2007+A2:20100, IEC 61000-4-4:2012,
IEC 61000-4-5:2014, IEC 61000-4-6:2013, IEC 61000-4-8:2009, IEC 61000-4-11:2004)

The device described above is tested by Shenzhen RCT testing technology Co.,Ltd to determine the maximum emission levels emanating from the device and the severe levels of the device can endure and its performance criterion. The measurement results are contained in this test report and Shenzhen RCT testing technology Co.,Ltd is assumed full of responsibility for the accuracy and completeness of these measurements. Also, this report shows that the EUT (Equipment Under Test) is technically compliant with the EN 61000-6-3, EN 61000-3-2, EN 61000-3-3 and EN 61000-6-2 requirements.

This report applies to above tested sample only and shall not be reproduced in part without written approval of Shenzhen RCT testing technology Co.,Ltd.

Date of Test : Aug 02, 2020 to Aug 23, 2020

Prepared by : Jessie Hu/Editor

Reviewer : Neo Dong/Supervisor

Approved & Authorized Signer : Christy Chen/Manager

Modified Information

Version	Report No.	Revision Date	Summary
Ver.1.0	RCT20200824002EMC	/	Original Report

1.

SUMMARY OF TEST RESULT

EMISSION			
Description of test item	Standard	Limits	Results
Conducted disturbance at mains terminals	EN 61000-6-3:2007+ A1:2011+ AC:2012	Class B	Pass
Radiated Disturbance	EN 61000-6-3:2007+ A1:2011+ AC:2012	Class B	Pass
Harmonic current emissions	EN 61000-3-2:2014	Class A	Pass
Voltage fluctuation and flicker	EN61000-3-3:2013	Section 5	Pass
Immunity(EN61000-6-2)			
Description of test item	Basic Standard	Performance Criteria	Results
Electrostatic Discharge (ESD)	IEC 61000-4-2:2008	B	Pass
Radio-frequency, Continuous radiated disturbance	IEC 61000-4-3:2006+ A1:2007+A2:2010	A	Pass
EFT/B Immunity	IEC 61000-4-4:2012	B	Pass
Surge Immunity	IEC 61000-4-5:2014	B	Pass
Conducted RF Immunity	IEC 61000-4-6:2013	A	Pass
Power frequency magnetic field	IEC 61000-4-8:2009	A	Pass
Voltage dips	IEC 61000-4-11:2004	B/C	Pass
Voltage interruptions		C	Pass
Note: N/A is an abbreviation for Not Applicable.			

2. GENERAL INFORMATION

2.1. Description of Device (EUT)

EUT : Micro Inverter
Model Number : WVC-295, WVC-300, WVC-350, WVC-600, WVC-700, WVC-1200, WVC-1400, WVC-2000, WVC-2400, WVC-2800
Test Voltage : AC 230V/50HZ or DC 50V
Applicant : Dongguan kaideng Energy Technology Co., Ltd.
Address : 4 th floor, Fuyuan business building, no. 1, Lane 13, xin'an maiyuan Road, Chang 'an town, Dongguan City
Manufacturer : Dongguan kaideng Energy Technology Co., Ltd.
Address : 4 th floor, Fuyuan business building, no. 1, Lane 13, xin'an maiyuan Road, Chang 'an town, Dongguan City
Date of receiver : Aug 02, 2020
Date of Test : Aug 02, 2020 to Aug 23, 2020

2.2. Description of Support Device

N/A

2.3. Description of Test Facility

Site Description
EMC Lab.

: Accredited by CNAS, 2013.10.29
The certificate is valid until 2016.10.29
The Laboratory has been assessed and proved to be in compliance with CNAS-CL01: 2006(identical to ISO/IEC17025: 2005)

Accredited by TUV Rheinland Shenzhen 2010.5
The Laboratory has been assessed according to the requirements ISO/IEC 17025.

Accredited by FCC, April 17, 2014
The Certificate Registration Number is 709623.

Accredited by Industry Canada, November 29, 2012
The Certificate Registration Number is 46405-4480.

Name of Firm : Shenzhen RCT testing technology Co.,Ltd
Site Location : 1417, Junlan building, Guanlan District, Longhua, Shenzhen,Guangdong, China

2. 4.

Measurement Uncertainty

Test Item	Uncertainty
Conducted Emission Uncertainty	: 2.96dB(9k~150kHz Conduction 1#) 2.74dB(150k-30MHz Conduction 1#)
Radiated Emission Uncertainty (3m Chamber)	: 3.78dB (30M~1GHz Polarize: H) 4.27dB (30M~1GHz Polarize: V)
Uncertainty for Flicker test	: 0.07%
Uncertainty for Harmonic test	: 1.8%
Uncertainty for C/S Test	: 1.45(Using CDN Test)
Uncertainty for R/S Test	: 2.10dB(80MHz-200MHz) 1.76dB(200MHz-1000MHz)
Uncertainty for test site temperature and humidity	: 0.6°C 4%

3. MEASURING DEVICE AND TEST EQUIPMENT

3.1. For Power Line Conducted Emission

Used	Equipment	Manufacturer	Model No.	Serial No.	Last Cal.	Cal. Interval
<input checked="" type="checkbox"/>	Test Receiver	Rohde & Schwarz	ESCI	26115-010-00 27	May 16, 2020	1 Year
<input checked="" type="checkbox"/>	L.I.S.N.	Rohde & Schwarz	ENV216	101161	May 16, 2020	1 Year
<input checked="" type="checkbox"/>	50Ω Coaxial Switch	Anritsu	MP59B	6100175589	May 17, 2020	1 Year
<input checked="" type="checkbox"/>	Voltage Probe	Rohde & Schwarz	ESH2-Z3	100122	May 16, 2020	1 Year

3.2. For Radiated Emission Measurement

Item	Equipment	Manufacturer	Model No.	Serial No.	Last Cal.	Cal. Interval
<input checked="" type="checkbox"/>	EMI Test Receiver	Rohde & Schwarz	ESU	1302.6005.26	May 17, 2020	1 Year
<input checked="" type="checkbox"/>	Pre-Amplifier	HP	8447F	2944A07999	May 16, 2020	1 Year
<input checked="" type="checkbox"/>	Bilog Antenna	Schwarzbeck	VULB9163	142	Jan 24, 2020	1 Year
<input checked="" type="checkbox"/>	Cable	Schwarzbeck	AK9513	ACRX1	May 16, 2020	1 Year
<input checked="" type="checkbox"/>	Cable	Rosenberger	N/A	FP2RX2	May 16, 2020	1 Year
<input checked="" type="checkbox"/>	Cable	Schwarzbeck	AK9513	CRPX1	May 16, 2020	1 Year
<input checked="" type="checkbox"/>	Cable	Schwarzbeck	AK9513	CRRX2	May 16, 2020	1 Year

3.3. For Harmonic Current / Flicker Measurement

Used	Equipment	Manufacturer	Model No.	Serial No.	Last Cal.	Cal. Interval
<input checked="" type="checkbox"/>	45KVA AC Power source	Teseq	NSG 1007-45/45K VA	1305A02873	May 16, 2020	1 Year
<input checked="" type="checkbox"/>	Signal conditioning Unit	Teseq	CCN 1000-3	1305A02873	May 16, 2020	1 Year
<input checked="" type="checkbox"/>	Three phase impedance network	Teseq/Germany	INA2197/37A	1305A02873	N/A	N/A
<input checked="" type="checkbox"/>	Three phase impedance network	Teseq/Germany	INA 2196/75A	1305A02874	N/A	N/A
£	Proflin 2100 AC Switching Unit	Teseq/Germany	NSG2200-3	A22714	N/A	N/A

3.4. For Electrostatic Discharge Immunity Test

Used	Equipment	Manufacturer	Model No.	Serial No.	Last Cal.	Cal. Interval
<input checked="" type="checkbox"/>	ESD Tester	TESEQ AG	NSG 438A	130	May 16, 2020	1 Year
<input checked="" type="checkbox"/>	Impulse Module	TESEQ AG	INA 4380-150pF /330Ohm	403-550/1712	May 16, 2020	1 Year

3. 5.

For RF Strength Susceptibility Test

Used	Equipment	Manufacturer	Model No.	Serial No.	Last Cal.	Cal. Interval
<input checked="" type="checkbox"/>	Signal Generator	Agilent	N5181A	MY50145187	May 16, 2020	1 Year
<input checked="" type="checkbox"/>	RF Power Meter. Dual Channel	BOONTON	4232A	10539	May 16, 2020	1 Year
<input checked="" type="checkbox"/>	50ohm Diode Power Sensor	BOONTON	51011EMC	34236/34238	May 16, 2020	1 Year
<input checked="" type="checkbox"/>	Field Strength Meter	DARE	RSS1006A	10I00037SO22	May 16, 2020	1 Year
<input checked="" type="checkbox"/>	50ohm Diode Power Sensor	BOONTON	51011EMC	36164	May 16, 2020	1 Year
<input checked="" type="checkbox"/>	Power Amplifier	MILMEGA	80RF1000-175	1059345	May 16, 2020	1 Year
£	Power Amplifier	MILMEGA	AS0102-55	1018770	May 16, 2020	1 Year
£	Power Amplifier	MILMEGA	AS1860-50	1059346	May 16, 2020	1 Year
<input checked="" type="checkbox"/>	Log.-Per. Antenna	SCHWARZBECK	VULP 9118E	N/A	May 16, 2020	1 Year
£	Broad-Band Horn Antenna	SCHWARZBECK	STLP 9149	9149-227	May 16, 2020	1 Year
<input checked="" type="checkbox"/>	Multi-function interface system	DARE	CTR1009B	12I00250SNO72	N/A	N/A
<input checked="" type="checkbox"/>	Automatic switch group	DARE	RSW1004A	N/A	N/A	N/A

3. 6.

For Electrical Fast Transient /Burst Immunity Test

Used	Equipment	Manufacturer	Model No.	Serial No.	Last Cal.	Cal. Interval
<input checked="" type="checkbox"/>	Burst Tester	HAEFELY	PEFT4010	080981-16	May 16, 2020	1Year
£	Coupling Clamp	HAEFELY	IP-4A	147147	May 16, 2020	1 Year

For Surge Immunity Test

Used	Equipment	Manufacturer	Model No.	Serial No.	Last Cal.	Cal. Interval
<input checked="" type="checkbox"/>	Surge Controller	HAEFELY	Psurge 8000	174031	May 16, 2020	1 Year
<input checked="" type="checkbox"/>	Impulse Module	HAEFELY	PIM 100	174124	May 16, 2020	1 Year
<input checked="" type="checkbox"/>	Coupling Decoupling Filter	HAEFELY	PCD 130	172181	May 16, 2020	1 Year
£	Coupling Module	HAEFELY	PCD122	174354	May 16, 2020	1 Year
£	Surge Impulse Module	HAEFELY	PIM 120	174435	May 16, 2020	1 Year
£	Coupling Module	HAEFELY	PCD 126A	174387	May 16, 2020	1 Year
£	Impulse Module	HAEFELY	PIM 110	174391	May 16, 2020	1 Year

3. 8.

For Injected Current Susceptibility Test

Used	Equipment	Manufacturer	Model No.	Serial No.	Last Cal.	Cal. Interval
<input checked="" type="checkbox"/>	Simulator	EMTEST	CWS500C	0900-12	May 16, 2020	1Year
£	CDN	EMTEST	CDN-M2	5100100100	May 16, 2020	1Year
<input checked="" type="checkbox"/>	CDN	EMTEST	CDN-M3	0900-11	May 16, 2020	1Year
£	Injection Clamp	EMTEST	F-2031-23MM	368	May 16, 2020	1Year
<input checked="" type="checkbox"/>	Attenuator	EMTEST	ATT6	0010222A	May 16, 2020	1Year

3. 9.

For Magnetic Field Immunity Test

Used	Equipment	Manufacturer	Model No.	Serial No.	Last Cal.	Cal. Interval
<input checked="" type="checkbox"/>	Magnetic Field Tester	HAEFELY	MAG100	250040.1	May 16, 2020	1 Year

3. 10.

For Voltage Dips and Interruptions Test

Used	Equipment	Manufacturer	Model No.	Serial No.	Last Cal.	Cal. Interval
<input checked="" type="checkbox"/>	45KVA AC Power source	Teseq	NSG 1007-45/45K VA	1305A02873	May 16, 2020	1 Year
£	Signal conditioning Unit	Teseq	CCN 1000-3	1305A02873	May 16, 2020	1 Year
£	Three phase impedance network	Teseq/Germany	INA2197/37A	1305A02873	May 16, 2020	1 Year
£	Three phase impedance network	Teseq/Germany	INA 2196/75A	1305A02874	May 16, 2020	1 Year
<input checked="" type="checkbox"/>	Proflin 2100 AC Switching Unit	Teseq/Germany	NSG2200-3	A22714	May 16, 2020	1 Year

4. POWER LINE CONDUCTED EMISSION MEASUREMENT

4.1. Block Diagram of Test Setup

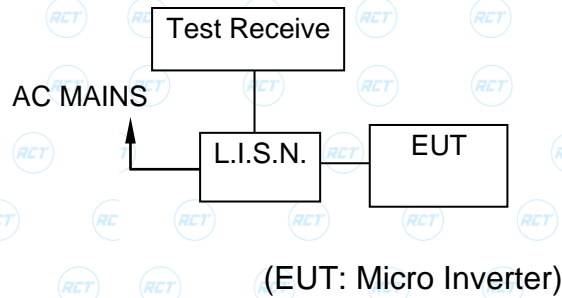

4.2. Measuring Standard EN 61000-6-3:2007+A1:2011+AC:2012

4.3. Power Line Conducted Emission Limits

Frequency (MHz)	Limit (dB μ V)	
	Quasi-peak Level	Average Level
0.15 ~ 0.50	66.0 ~ 56.0 *	56.0 ~ 46.0 *
0.50 ~ 5.00	56.0	46.0
5.00 ~ 30.00	60.0	50.0

NOTE1-The lower limit shall apply at the transition frequencies.
NOTE2-The limit decreases linearly with the logarithm of the frequency in the range 0.15MHz to 0.50MHz.

4.4. EUT Configuration on Measurement

The following equipments are installed on Conducted Emission Measurement to see EN 61000-6-3 requirements and operating in a manner which tends to maximize its emission characteristics in normal application.

Photovoltaic & Grid energy storage power supply (EUT)

Model No. : WVC-1400

Serial No. : N/A

4.5. Operating Condition of EUT

- 4.5.1. Setup the EUT as shown on Section 4.1.
- 4.5.2. Turn on the power of all equipments.
- 4.5.3. Let the EUT work in measuring mode (AC Charging) and measure it.

4. 6. **Test Procedure**

The EUT is put on the plane 0.8m high above the ground by insulating support and connected to the AC mains through Line Impedance Stability Network (L.I.S.N). This provided 50-ohm coupling impedance for the tested equipments. Both sides of AC line are investigated to find out the maximum conducted emission according to the EN61000-6-3 regulations during conducted emission measurement.

The bandwidth of the field strength meter (R&S Test Receiver ESCS30) is set at 9KHz in 150KHz~30MHz and 200Hz in 9KHz~150KHz.

The frequency range from 150kHz to 30MHz is investigated
All the scanning waveform is put in the following pages.

4. 7. **Measuring Results**

PASS.

Please reference to the following pages.

80.0 dBuV

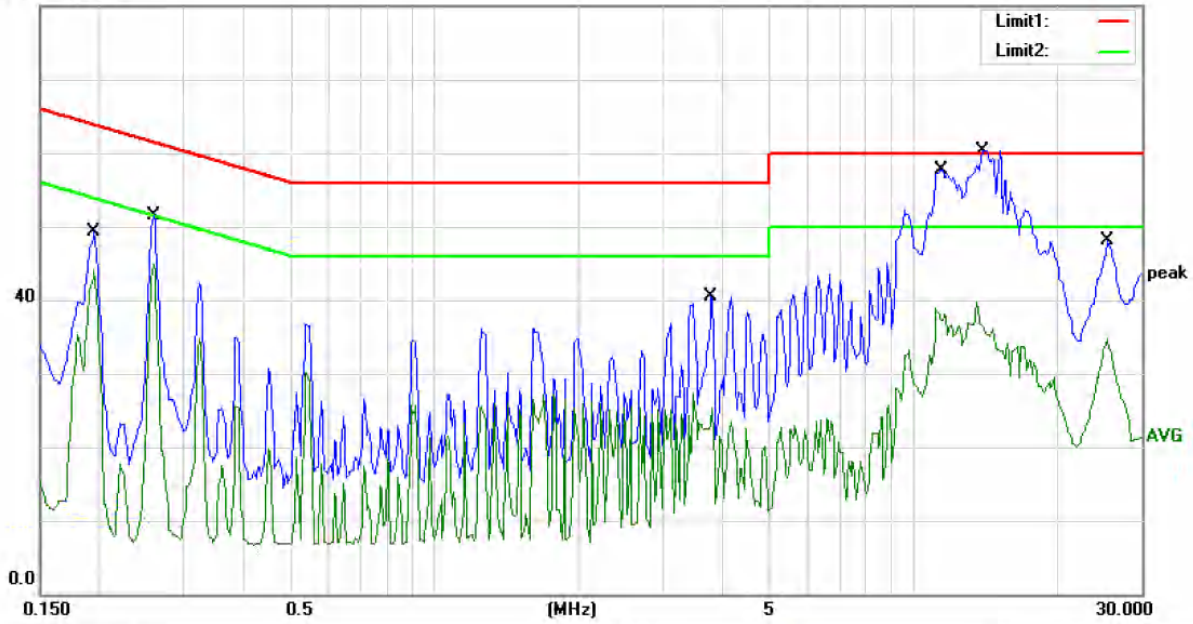

Site Conduction #2

Phase: **L1**

Temperature: 26

Limit: (CE)EN61000-6-3_QP

Power: AC 230V/50Hz

Humidity: 55 %

Mode: Charging

Note:

No.	Mk.	Freq.	Reading Level	Correct Factor	Measurement	Limit	Over	Detector	Comment
		MHz	dBuV	dB	dBuV	dBuV	dB		
1		0.1950	46.30	0.00	46.30	63.82	-17.52	QP	
2		0.1950	44.13	0.00	44.13	53.82	-9.69	AVG	
3		0.2600	48.70	0.00	48.70	61.43	-12.73	QP	
4		0.2600	44.83	0.00	44.83	51.43	-6.60	AVG	
5		3.7950	36.80	0.00	36.80	56.00	-19.20	QP	
6		3.7950	25.21	0.00	25.21	46.00	-20.79	AVG	
7		11.4750	53.90	0.00	53.90	60.00	-6.10	QP	
8		11.4750	38.60	0.00	38.60	50.00	-11.40	AVG	
9	*	13.9250	54.00	0.00	54.00	60.00	-6.00	QP	
10		13.9250	39.65	0.00	39.65	50.00	-10.35	AVG	
11		25.4500	44.60	0.00	44.60	60.00	-15.40	QP	
12		25.4500	34.76	0.00	34.76	50.00	-15.24	AVG	

*:Maximum data

x:Over limit

!:over margin

Comment: Factor build in receiver.

Operator: HJ

80.0 dBuV

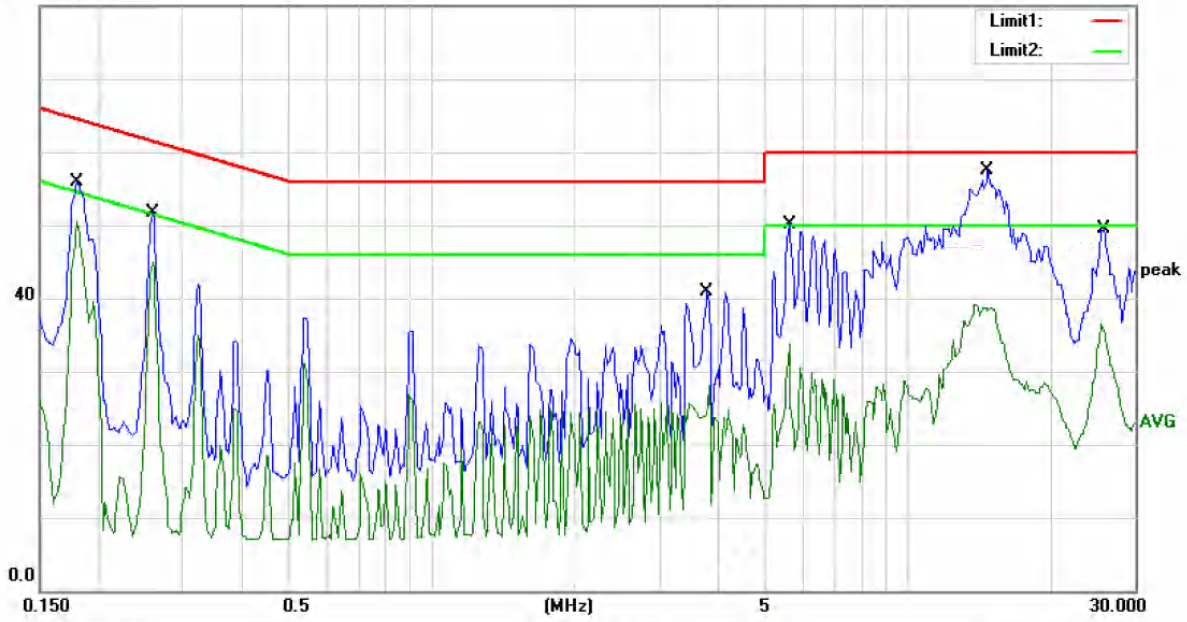

Site Conduction #2

Phase: **N**

Temperature: 26

Limit: (CE)EN61000-6-3_QP

Power: AC 230V/50Hz

Humidity: 55 %

Mode: Charging

Note:

No.	Mk.	Freq. MHz	Reading Level dBuV	Correct Factor dB	Measure- ment dBuV	Limit dBuV	Over dB	Detector	Comment
1		0.1800	52.80	0.00	52.80	64.49	-11.69	QP	
2	*	0.1800	50.41	0.00	50.41	54.49	-4.08	AVG	
3		0.2600	48.60	0.00	48.60	61.43	-12.83	QP	
4		0.2600	43.85	0.00	43.85	51.43	-7.58	AVG	
5		3.7850	40.82	0.00	40.82	56.00	-15.18	QP	
6		3.7850	28.01	0.00	28.01	46.00	-17.99	AVG	
7		5.6500	47.40	0.00	47.40	60.00	-12.60	QP	
8		5.6500	33.69	0.00	33.69	50.00	-16.31	AVG	
9		14.7000	53.60	0.00	53.60	60.00	-6.40	QP	
10		14.7000	38.79	0.00	38.79	50.00	-11.21	AVG	
11		25.7750	46.00	0.00	46.00	60.00	-14.00	QP	
12		25.7750	36.47	0.00	36.47	50.00	-13.53	AVG	

*:Maximum data x:Over limit !:over margin Comment: Factor build in receiver. Operator: HJ

5. RADIATED EMISSION MEASUREMENT

5.1. Block Diagram of Test

5.1.1. Block diagram of connection between the EUT and simulators



(EUT: Micro Inverter)

5.1.2. Block diagram of test setup (In chamber)

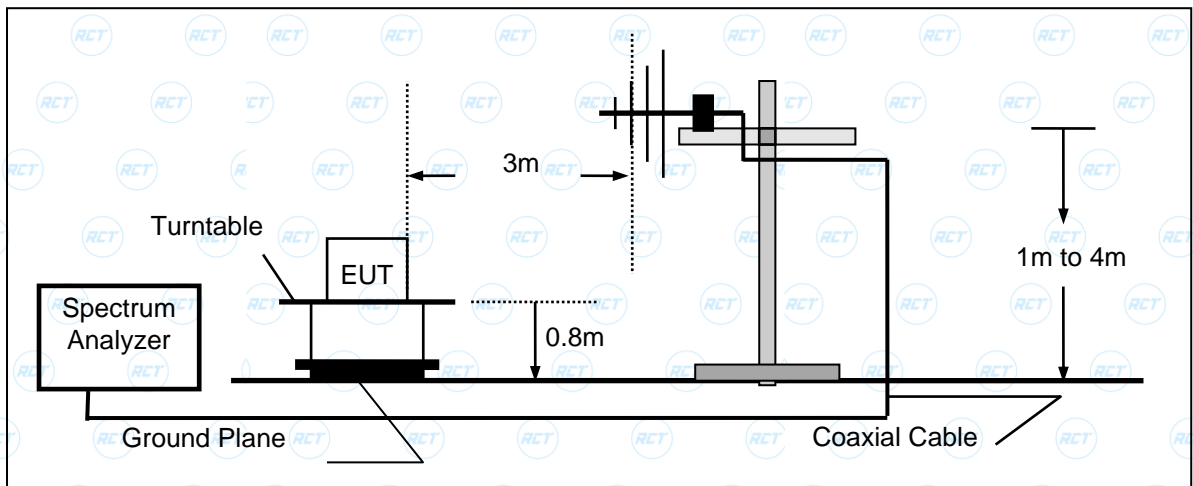

(EUT: Micro Inverter)

5.2. Measuring Standard

EN 61000-6-3:2007+A1:2011+AC:2012

5.3. Radiated Emission Limits

FREQUENCY (MHz)	DISTANCE (Meters)	FIELD STRENGTHS LIMIT (dB μ V/m)
30 ~ 230	3	40
230 ~ 1000	3	47

Note: (1) The smaller limit shall apply at the combination point between two frequency bands.
(2) Distance refers to the distance in meters between the measuring instrument antenna and the closed point of any part of the EUT.

5. 4. EUT Configuration on Measurement

The EN 61000-6-3 regulations test method must be used to find the maximum emission during radiated emission measurement.

Photovoltaic & Grid energy storage power supply (EUT)

Model No. : WVC-1400

Serial No. : N/A

5. 5. Operating Condition of EUT

5. 5. 1. Setup the EUT as shown on Section 5.1.

5. 5. 2. Turn on the power of all equipments.

5. 5. 3. Let the EUT work in measuring mode (Charging, Discharging) and measure it.

5. 6. Test Procedure

The EUT is placed on a turntable, which is 0.8 meter high above the ground. The turntable can rotate 360 degrees to determine the position of the maximum emission level. The EUT is set 3 meters away from the receiving antenna, which is mounted on a antenna tower. The antenna can be moved up and down from 1 to 4 meters to find out the maximum emission level. Bilog antenna (calibrated by Dipole Antenna) is used as a receiving antenna. Both horizontal and vertical polarization of the antenna is set on test.

The bandwidth of the Receiver is set at 120kHz.

All the scanning curves are attached in the following pages.

5. 7. Measuring Results

PASS.

The frequency range from 30MHz to 1000MHz is investigated.

Please reference to the following pages

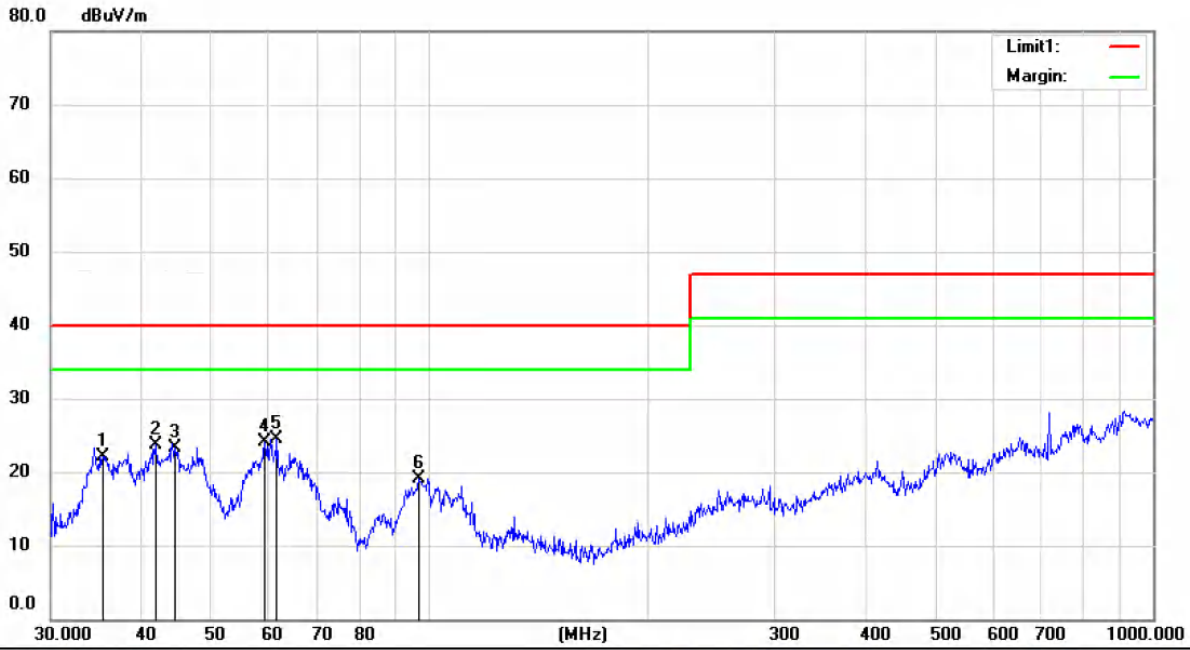

Site 3m Chamber #1

Polarization: **Horizontal**

Temperature: 22 C

Limit: (RE)EN61000-6-3_QP

Power: AC 230V/50Hz

Humidity: 50 %

Mode: AC Charging

Note:

No.	Mk.	Freq. MHz	Reading Level dBuV	Correct Factor dB	Measure- ment dBuV/m	Limit dBuV/m	Over dB	Antenna Height cm	Table Degree degree	Comment
1		35.3750	35.41	-13.22	22.19	40.00	-17.81	QP		
2		41.8594	36.31	-12.66	23.65	40.00	-16.35	QP		
3		44.5867	34.94	-11.73	23.21	40.00	-16.79	QP		
4		59.2323	38.03	-13.86	24.17	40.00	-15.83	QP		
5	*	61.5617	38.64	-14.18	24.46	40.00	-15.54	QP		
6		96.7750	33.23	-14.05	19.18	40.00	-20.82	QP		

*:Maximum data x:Over limit !:over margin

Operator: HYL

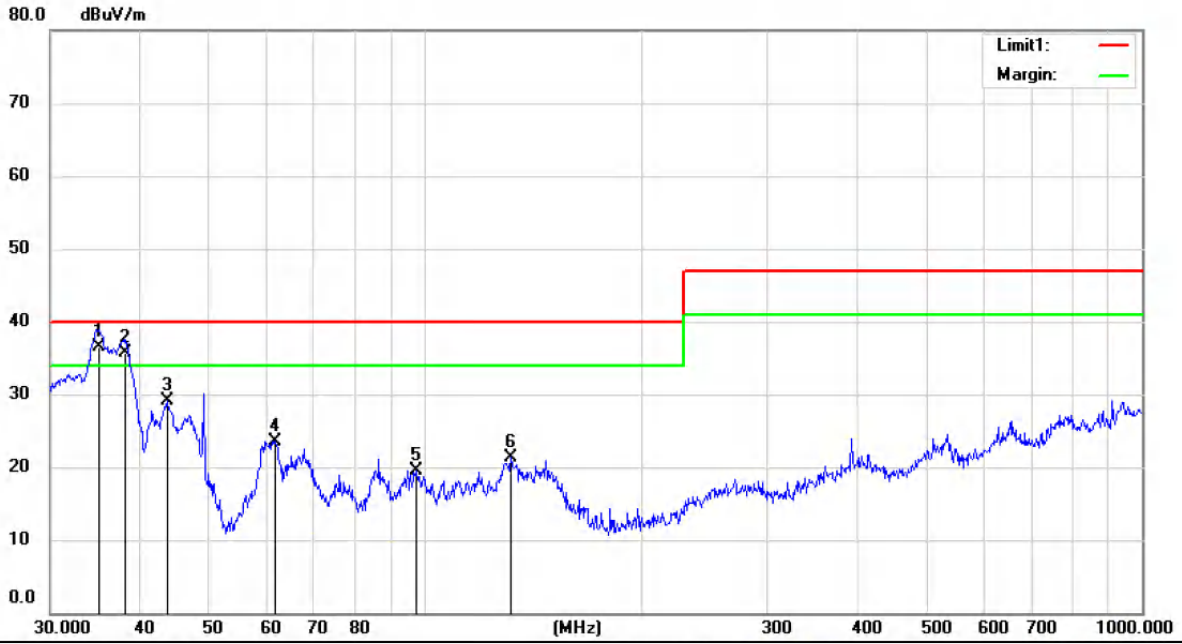

Site 3m Chamber #1

Polarization: **Vertical**

Temperature: 22 C

Limit: (RE)EN61000-6-3_QP

Power: AC 230V/50Hz

Humidity: 50 %

Mode: AC Charging

Note:

No.	Mk.	Freq. MHz	Reading Level dBuV	Correct Factor dB	Measure- ment dBuV/m	Limit dBuV/m	Over dB	Antenna Height cm	Table Degree degree	Comment
1	*	35.0048	49.80	-13.30	36.50	40.00	-3.50	QP		
2	!	38.2120	48.18	-12.38	35.80	40.00	-4.20	QP		
3		43.6584	40.72	-11.56	29.16	40.00	-10.84	QP		
4		61.7780	37.87	-14.28	23.59	40.00	-16.41	QP		
5		97.1148	33.42	-14.00	19.42	40.00	-20.58	QP		
6		131.7577	37.68	-16.43	21.25	40.00	-18.75	QP		

*:Maximum data x:Over limit !:over margin

Operator: HYL

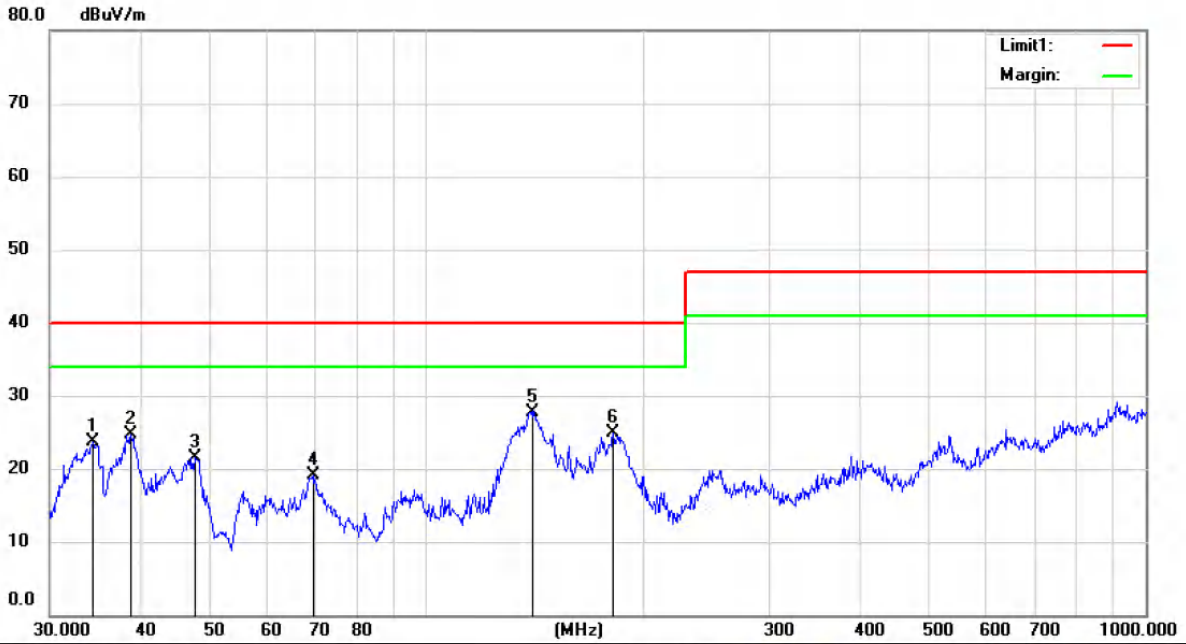

Site 3m Chamber #1

Polarization: **Horizontal**

Temperature: 22 C

Limit: (RE)EN61000-6-3_QP

Power: DC 50V

Humidity: 50 %

Mode: Discharging

Note:

No.	Mk.	Freq. MHz	Reading Level dBuV	Correct Factor dB	Measure- ment dBuV/m	Limit dBuV/m	Over dB	Antenna Height cm	Table Degree	Detector	Comment
1		34.3964	37.08	-13.43	23.65	40.00	-16.35			QP	
2		38.8878	37.11	-12.46	24.65	40.00	-15.35			QP	
3		47.6584	34.15	-12.66	21.49	40.00	-18.51			QP	
4		69.6004	36.94	-17.79	19.15	40.00	-20.85			QP	
5	*	140.8350	44.85	-17.05	27.80	40.00	-12.20			QP	
6		181.9202	42.22	-17.27	24.95	40.00	-15.05			QP	

*:Maximum data x:Over limit !:over margin

Operator: HYL

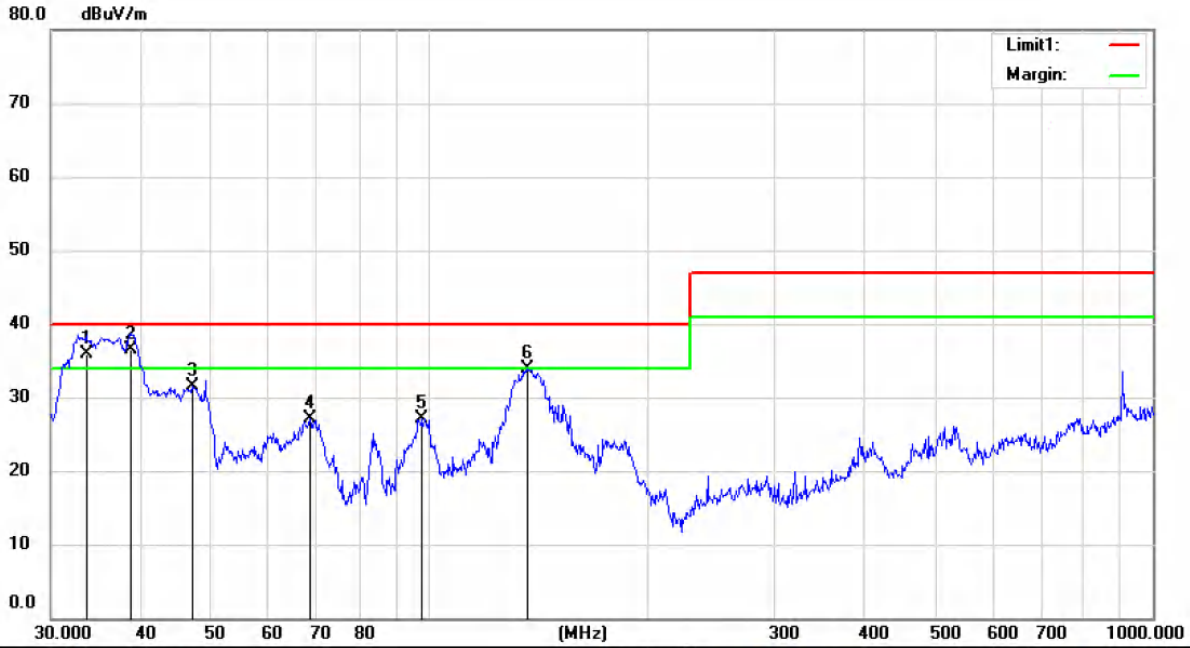

Site 3m Chamber #1

Polarization: **Vertical**

Temperature: 22 C

Limit: (RE)EN61000-6-3_QP

Power: DC 50V

Humidity: 50 %

Mode: Discharging

Note:

No.	Mk.	Freq. MHz	Reading Level dBuV	Correct Factor dB	Measure- ment dBuV/m	Limit dBuV/m	Over dB	Detector	Antenna Height cm	Table Degree	Comment
1	!	33.5624	49.64	-13.64	36.00	40.00	-4.00	QP			
2	*	38.7518	49.05	-12.45	36.60	40.00	-3.40	QP			
3		46.9947	44.21	-12.68	31.53	40.00	-8.47	QP			
4		68.3908	44.40	-17.31	27.09	40.00	-12.91	QP			
5		97.7983	41.09	-13.91	27.18	40.00	-12.82	QP			
6		136.4598	50.60	-16.68	33.92	40.00	-6.08	QP			

*:Maximum data x:Over limit !:over margin

Operator: HYL

6. HARMONIC CURRENT EMISSION

MEASUREMENT

6.1. Block Diagram of Test Setup

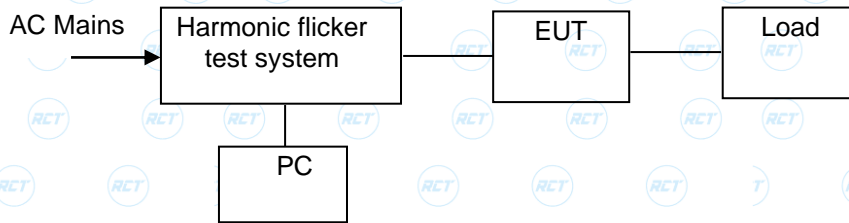

(EUT: Micro Inverter)

6.2. Measuring Standard

EN 61000-3-2:2014 CLASS A

6.3. Operation Condition of EUT

6.3.1. Turn on the power.

6.3.2. After that, let the EUT work in test mode (AC Charging & Discharging) and measure it.

6.4. Measuring Results

PASS.

Please refer to the following pages.

7. VOLTAGE FLUCTUATION AND FLICKER MEASUREMENT

7.1. Block Diagram of Test Setup

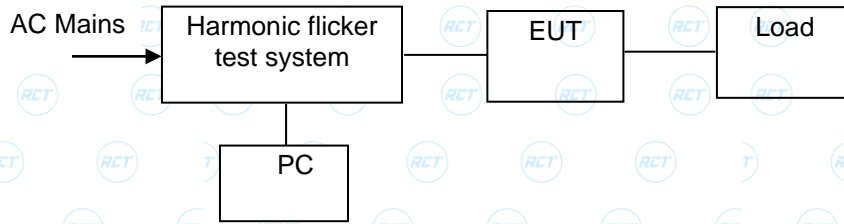

(EUT: Micro Inverter)

7.2. Measuring Standard

EN 61000-3-3:2013

7.3. Operation Condition of EUT

7.3.1. Turn on the power.

7.3.2. After that, let the EUT work in test mode (AC Charging & Discharging) and measure it.

7.4. Measuring Results

PASS.

Please see the attached page.

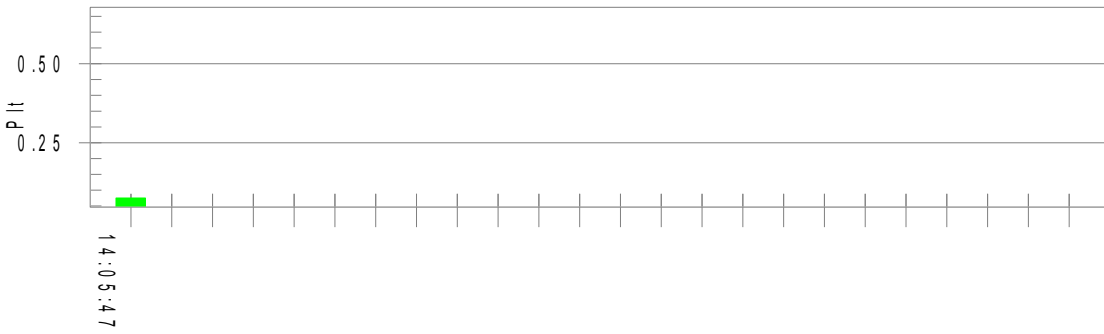
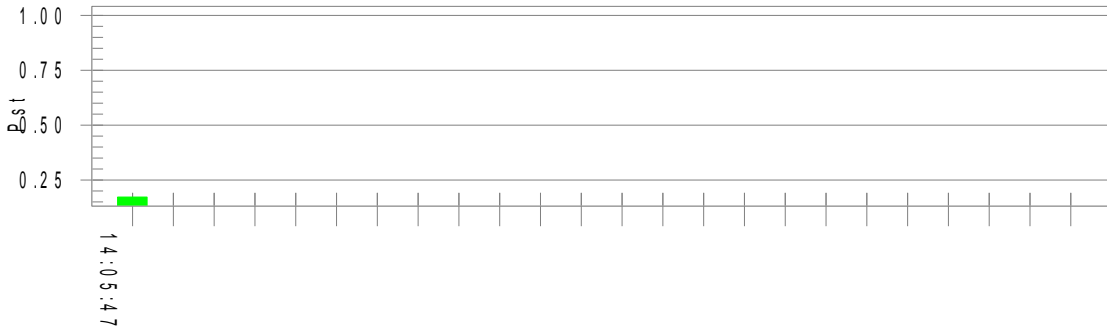

8.

IMMUNITY PERFORMANCE CRITERIA

DESCRIPTION

Performance Level

The test results shall be classified in terms of the loss of function or degradation of performance of the equipment under test, relative to a performance level by its manufacturer or the requestor of the test, or the agreed between the manufacturer and the purchaser of the product.

Definition related to the performance level:

1. Based on the used product standard
2. Based on the declaration of the manufacturer, requestor or purchaser

Criterion A:

Definition: normal performance within limits specified by the manufacturer, requestor and purchaser.

The equipment shall continue to operate as intended without operator intervention. No degradation of performance or loss of function is allowed below a performance level specified by the manufacturer when the equipment is used as intended. The performance level may be replaced by a permissible loss of performance. If the minimum performance level or the permissible performance loss is not specified by the manufacturer, then either of these may be derived from the product description and documentation, and by what the user may reasonably expect from the equipment if used as intended.

Criterion B:

Definition: temporary loss of function or degradation of performance which ceases after the disturbance ceases, and from which the equipment under test recovers its normal performance, without operator intervention.

After the test, the EUT shall continue to operate as intended without operator intervention. No degradation of performance or loss of function is allowed, after the application of the phenomena below a performance level specified by the manufacturer, when the EUT is used as intended. The performance level may be replaced by a permissible loss of performance. During the test, degradation of performance is allowed. However, no change of operating state or stored data is allowed to persist after the test. If the minimum performance level (or the permissible performance loss) is not specified by the manufacturer, then either of these may be derived from the product description and documentation, and by what the user may reasonably expect from the EUT if used as intended.

Criterion C:

Definition: temporary loss of function or degradation of performance, the correction of which requires operator intervention.

Loss of function is allowed, provided the function is self-recoverable, or can be restored by the operation of the controls by the user in accordance with the manufacturer's instructions. Functions, and/or information stored in non-volatile memory, or protected by a battery backup, shall not be lost.

Criterion D

Definition: loss of function or degradation of performance, which is not recoverable, owing to damage to hardware or software, or loss of data.

9. ELECTROSTATIC DISCHARGE IMMUNITY TEST

9.1. Block Diagram of Test Setup

9.1.1. Block diagram of connection between the EUT and simulators



(EUT: Micro Inverter)

9.1.2. Block diagram of ESD test setup

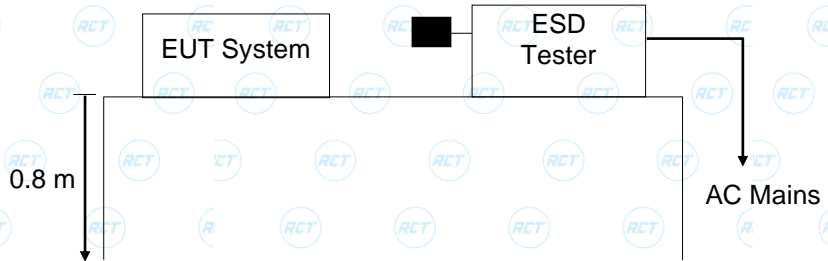

(EUT: Micro Inverter)

9.2. Test Standard

EN 61000-6-2:2005

(IEC 61000-4-2:2008 Severity Level: 3 / Air Discharge: $\pm 8\text{KV}$

Level: 2 / Contact Discharge: $\pm 4\text{KV}$)

9.3. Severity Levels and Performance Criterion

9.3.1. Severity level

Level	Test Voltage Contact Discharge (KV)	Test Voltage Air Discharge (KV)
1.	± 2	± 2
2.	± 4	± 4
3.	± 6	± 8
4.	± 8	± 15
X	Special	Special

9.3.2. Performance Criterion: B

9.4. **EUT Configuration**

The configuration of EUT is listed in Section 4.4.

9.5. **Operating Condition of EUT**

Same as conducted emission measurement, which is listed in Section 4.5. Except the test set up replaced by Section 9.1.

9.6. **Test Procedure**

9.6.1. **Air Discharge:**

This test is done on a non-conductive surface. The round discharge tip of the discharge electrode shall be approached as fast as possible to touch the EUT.

After each discharge, the discharge electrode shall be removed from the EUT.

The generator is then re-triggered for a new single discharge and repeated 10 times for each pre-selected test point. This procedure shall be repeated until all the air discharge completed

9.6.2. **Contact Discharge:**

All the procedure shall be same as Section 9.6.1. Except that the tip of the discharge electrode shall touch the EUT before the discharge switch is operated.

9.6.3. **Indirect discharge for horizontal coupling plane**

At least 10 single discharges (in the most sensitive polarity) shall be applied at the front edge of each HCP opposite the center point of each unit (if applicable) of the EUT and 0.1m from the front of the EUT. The long axis of the discharge electrode shall be in the plane of the HCP and perpendicular to its front edge during the discharge.

9.6.4. **Indirect discharge for vertical coupling plane**

At least 10 single discharge (in the most sensitive polarity) shall be applied to the center of one vertical edge of the coupling plane. The coupling plane, of dimensions 0.5m X 0.5m, is placed parallel to, and positioned at a distance of 0.1m from the EUT. Discharges shall be applied to the coupling plane, with this plane in sufficient different positions that the four faces of the EUT are completely illuminated.

9.7. **Test Results**

PASS

Please refer to the following page.

Electrostatic Discharge Test Result

Shenzhen RCT testing technology Co.,Ltd

Applicant : Dongguan kaideng Energy Technology Co., Ltd.		
EUT : Micro Inverter	Test Date : Aug 15, 2020	
M/N : WVC-1400	Temperature : 24°C	
Power Supply : AC 230V/50HZ, DC 50V	Humidity : 53%	
Air discharge : ±8.0KV	Criterion : B	
Contact discharge: ±4.0KV	Test Engineer : LZC	
Test Mode : AC Charging & Discharging, Discharging		
Location	Kind A-Air Discharge C-Contact Discharge	Result
Slot	A	A
Button	A	A
Port	C	A
HCP	C	A
VCP of front	C	A
VCP of rear	C	A
VCP of left	C	A
VCP of right	C	A
Test Equipment: ESD Simulator		

10.

RF FIELD STRENGTH SUSCEPTIBILITY TEST

10.1. Block Diagram of Test

10.1.1. Block diagram of connection between the EUT and Load

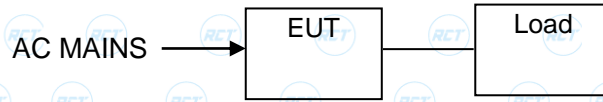

(EUT: Micro Inverter)

10.1.2. Block diagram of RS test setup

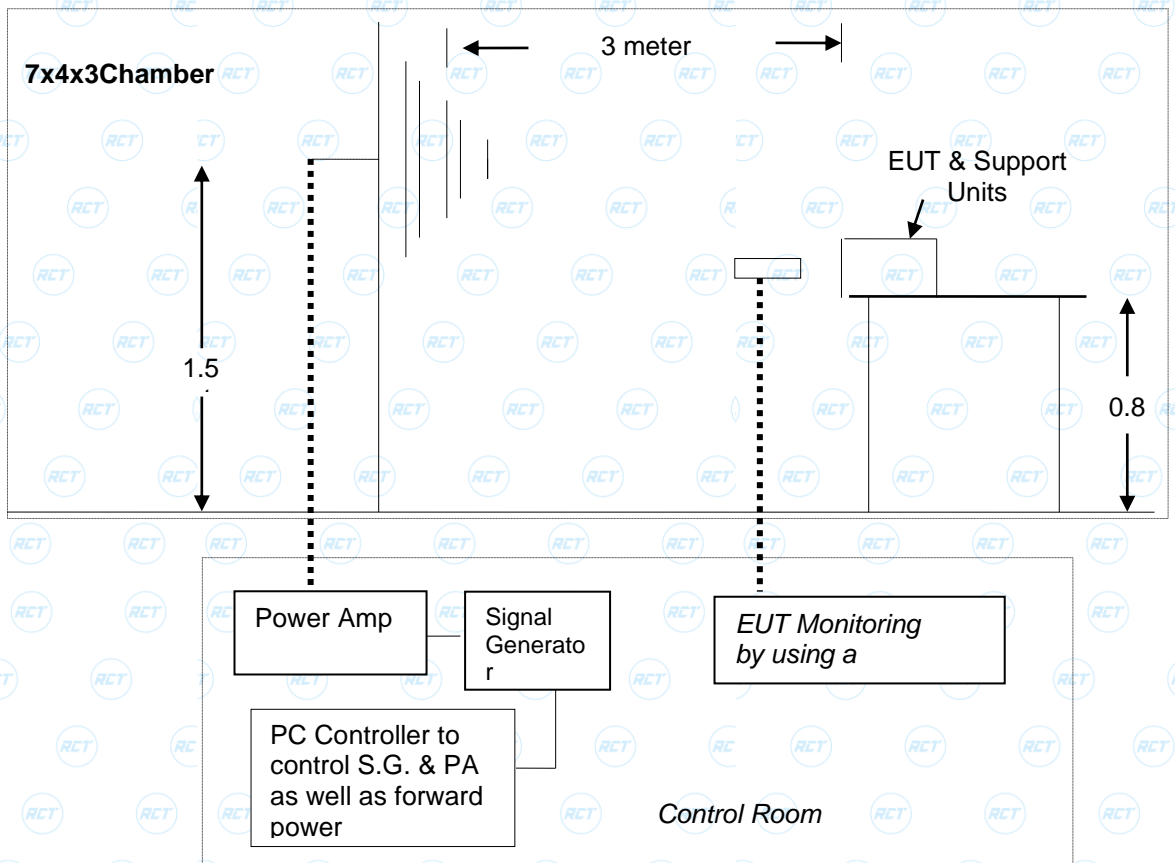

(EUT: Micro Inverter)

10.2. Test Standard

EN 61000-6-2:2005
(IEC 61000-4-3:2006+A1:2007+A2:2010, Severity Level 1: 1V/m (2G-2.7GHz),
Level 2: 3V/m (1.4GHz-2GHz), Level 3: 10V/m (80MHz-1GHz))

10.3. Severity Levels and Performance Criterion

10.3.1. Severity Levels

Level	Field Strength V/m
1.	1
2.	3
3.	10
X	Special

10.3.2. Performance Criterion: A

10.4. EUT Configuration on Test

The configuration of the EUT is same as Section 4.4.

10.5. Operating Condition of EUT

Same as radiated emission measurement, which is listed in Section 4.5, except the test setup replaced as Section 10.1.

10.6. Test Procedure

The EUT are placed on a table, which is 0.8 meter high above the ground. The EUT is set 3 meters away from the transmitting antenna, which is mounted on an antenna tower. Both horizontal and vertical polarization of the antenna is set on test. Each of the four sides of the EUT must be faced this transmitting antenna and measured individually. In order to judge the EUT performance, a CCD Recording is used to monitor its screen. All the scanning conditions are as following:

Condition of Test	Remark
1. Field Strength	1V/m (Severity Level 1) 3V/m (Severity Level 2) 10V/m (Severity Level 3)
2. Radiated Signal	Modulated 80-2700MHz
3. Scanning Frequency	0.0015 Decade/s
4. Sweep time of radiated	1 Sec.
5. dwell Time	

10.7. Test Results

PASS.

Please refer to the following page

RF Field Strength Susceptibility Test Results

Shenzhen RCT testing technology Co.,Ltd

Applicant : Dongguan kaideng Energy Technology Co., Ltd.			
EUT : Micro Inverter		Test Date : Aug 15, 2020	
M/N : WVC-1400		Temperature : 22°C	
Field Strength : 10V/m		Humidity : 55 %	
Power Supply : AC 230V/50HZ		Criterion : A	
Test Mode : AC Charging & Discharging		Frequency Range: 80 MHz to 1000 MHz	
Test Engineer: LZC			
Modulation: None		Pulse AM 1KHz 80%	
Frequency Rang 1: 80~ 1000MHz		Frequency Rang 2: N/A	
Steps	# / %	# / %	# / %
	Horizontal	Vertical	Horizontal
Front	A	A	
Right	A	A	
Rear	A	A	
Left	A	A	
Test Equipment : 1. Signal Generator : N5181A (Agilent) 2. Power Amplifier : AS0102-55 (MILMEGA) & 80RF1000-175 (MILMEGA) & AS1860-50 (MILMEGA) 3. Log.-Per.Antenna: VULP9118E (SCHWARZBECK) 4. Broad-Band Horn Antenna: STLP 9149 (Schwarzbeck) 5. RF Power Meter. Dual Channel: 4232A (BOONTON) 6. Field Strength Meter: RSS1006A (DARE)			
Note:			

RF Field Strength Susceptibility Test Results

Shenzhen RCT testing technology Co.,Ltd

Applicant : Dongguan kaideng Energy Technology Co., Ltd.				
EUT : Micro Inverter		Test Date : Aug 15, 2020		
M/N : WVC-1400		Temperature : 22°C		
Field Strength : 3 V/m		Humidity : 55 %		
Power Supply : AC 230V/50HZ		Criterion : A		
Test Mode : AC Charging & Discharging		Frequency Range: 1400 MHz to 2000 MHz		
Test Engineer: LZC				
Modulation: None		Pulse AM 1KHz 80%		
Frequency Rang 1: 1400~ 2000MHZ		Frequency Rang 2: N/A		
Steps	1%			
	Horizontal	Vertical	Horizontal	Vertical
Front	A	A		
Right	A	A		
Rear	A	A		
Left	A	A		
Test Equipment : 1. Signal Generator : N5181A (Agilent) 2. Power Amplifier : AS0102-55 (MILMEGA) & 80RF1000-175 (MILMEGA) & AS1860-50 (MILMEGA) 3. Log.-Per.Antenna: VULP9118E (SCHWARZBECK) 4. Broad-Band Horn Antenna: STLP 9149 (Schwarzbeck) 5. RF Power Meter. Dual Channel: 4232A (BOONTON) 6. Field Strength Meter: RSS1006A (DARE)				
Note:				

RF Field Strength Susceptibility Test Results

Shenzhen RCT testing technology Co.,Ltd

Applicant : Dongguan kaideng Energy Technology Co., Ltd.				
EUT : Micro Inverter		Test Date : Aug 15, 2020		
M/N : WVC-1400		Temperature : 22°C		
Field Strength : 1 V/m		Humidity : 55 %		
Power Supply : AC 230V/50HZ		Criterion : A		
Test Mode : AC Charging & Discharging		Frequency Range: 2000 MHz to 2700 MHz		
Test Engineer: LZC				
Modulation: None		Pulse AM 1KHz 80%		
Frequency Rang 1: 2000~ 2700MHZ		Frequency Rang 2: N/A		
Steps 1%				
	Horizontal	Vertical	Horizontal	Vertical
Front	A	A		
Right	A	A		
Rear	A	A		
Left	A	A		
<p>Test Equipment :</p> <ol style="list-style-type: none"> 1. Signal Generator : N5181A (Agilent) 2. Power Amplifier : AS0102-55 (MILMEGA) & 80RF1000-175 (MILMEGA) & AS1860-50 (MILMEGA) 3. Log.-Per.Antenna: VULP9118E (SCHWARZBECK) 4. Broad-Band Horn Antenna: STLP 9149 (Schwarzbeck) 5. RF Power Meter. Dual Channel: 4232A (BOONTON) 6. Field Strength Meter: RSS1006A (DARE)) 				
Note:				

11. ELECTRICAL FAST TRANSIENT/BURST IMMUNITY TEST

11.1. Block Diagram of Test Setup

11.1.1. Block Diagram of the EUT

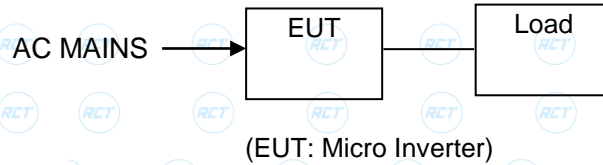

11.1.2. EFT Test Setup

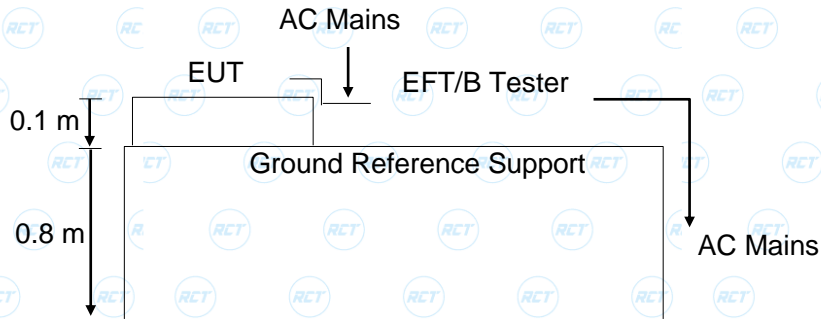

11.2. Test Standard

EN 61000-6-2:2005
(IEC 61000-4-4:2012, Severity Level, Level 3: 2KV)

11.3. Severity Levels and Performance Criterion

11.3.1. Severity level

Level	Open Circuit Output Test Voltage $\pm 10\%$	
	On Power Supply Lines	On I/O (Input/Output) Signal data and control lines
1.	0.5 KV	0.25 KV
2.	1 KV	0.5 KV
3.	2 KV	1 KV
4.	4 KV	2 KV
X	Special	Special

11.3.2. Performance Criterion : B

11.4. EUT Configuration

The configuration of EUT is listed in Section 4.4

11.5.

Operating Condition of EUT

11.5.1.

Setup the EUT as shown in Section 11.1.

11.5.2.

Turn on the power of all equipments.

11.5.3.

Let the EUT work in test mode (AC Charging & Discharging) and measure it.

11.6.

Test Procedure

The EUT is put on the table, which is 0.8 meter high above the ground. This reference ground plane shall project beyond the EUT by at least 0.1m on all sides and the minimum distance between EUT and all other conductive structure, except the ground plane beneath the EUT, shall be more than 0.5m.

11.6.1.

For input and output AC power ports:

The EUT is connected to the power mains by using a coupling device, which couples the EFT interference signal to AC power lines. Both polarities of the test voltage should be applied during compliance test and the duration of the test is 2 mins.

11.6.2.

For signal lines and control lines ports:

It's unnecessary to test.

11.6.3.

For DC output line ports:

It's unnecessary to test.

11.7.

Test Result

PASS.

Please refer to the following page.

Electrical Fast Transient/Burst Test Results

Shenzhen RCT testing technology Co.,Ltd

Standard	IEC 61000-4-4 EN 61000-4-4	Result: PASS / FAIL	
Applicant : <u>Dongguan kaideng Energy Technology Co., Ltd.</u>			
EUT : <u>Micro Inverter</u>			
M/N : <u>WVC-1400</u>			
Input Voltage: <u>AC 230V/50HZ</u>			
Criterion : <u>B</u>			
Ambient Condition : <u>24 °C</u> <u>53% RH</u>			
Operation Mode: AC Charging & Discharging			
Line : <u>AC Mains</u>	Line :	<u>Signal</u>	<u>I/O Cable</u>
Coupling : <u>Direct</u>	Coupling :	<u>Capacitive</u>	
Test Time : 120s			
Line	Test Voltage	Result (+)	Result (-)
L	2KV	A	A
N	2KV	A	A
PE	2KV	A	A
L、N	2KV	A	A
L、PE	2KV	A	A
N、PE	2KV	A	A
L、N、PE	2KV	A	A
Signal Line			
DC Line			
Note:			
Test Equipment		Burst Tester Model : PEFT 4010	

12.

SURGE IMMUNITY TEST

12.1.

Block Diagram of Test Setup

12.1.1.

Block Diagram of the EUT

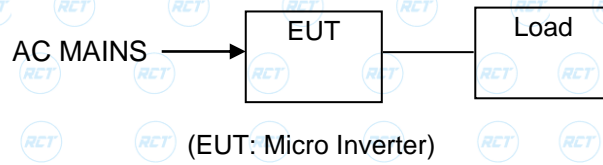

12.1.2.

Surge Test Setup

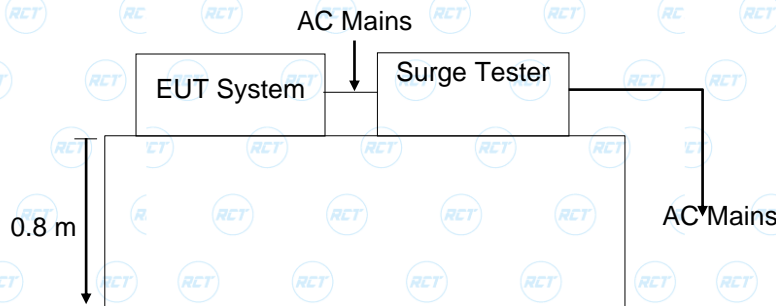

12.2.

Test Standard

EN 61000-6-2:2005
(IEC 61000-4-5:2014 Severity Level: Line to Line: Level 2, 1.0 KV,
Line to earth:
Level 3, 2.0 KV)

12.3.

Severity Levels and Performance Criterion

12.3.1.

Severity level

Severity Level	Open-Circuit Test Voltage KV
1	0.5
2	1.0
3	2.0
4	4.0
*	Special

12.3.2.

Performance Criterion : B

12.4.

EUT Configuration

The configuration of EUT is listed in Section 4.4

12. 5.

Operating Condition of EUT

12. 5. 1.

Setup the EUT as shown in Section 12.1.

12. 5. 2.

Turn on the power of all equipments.

12. 5. 3.

Let the EUT work in test mode (AC Charging & Discharging) and measure it.

12. 6.

Test Procedure

1)

Set up the EUT and test generator as shown on Section 12.1.2.

2)

For line to line coupling mode, provide a 1.0 KV 1.2/50us voltage surge
For line to earth coupling mode, provide a 2.0 KV 1.2/50us voltage surge
(at open-circuit condition) and 8/20us current surge to EUT selected points.

3)

At least 5 positive and 5 negative (polarity) tests with a maximum 1/min repetition rate are conducted during test.

4)

Different phase angles are done individually.

5)

Record the EUT operating situation during compliance test and decide the EUT immunity criterion for above each test.

12. 7.

Test Result

PASS.

Please refer to the following page.

Surge Immunity Test Result

Shenzhen RCT testing technology Co.,Ltd

Applicant: <u>Dongguan kaideng Energy Technology Co., Ltd.</u>				Test Date : <u>Aug 15, 2020</u>	
EUT : <u>Micro Inverter</u>				Temperature : <u>22°C</u>	
M/N : <u>WVC-1400</u>				Humidity : <u>55%</u>	
Power Supply: <u>AC 230V/50HZ</u>				Test Mode : <u>AC Charging & Discharging</u>	
Test Engineer: <u>LZC</u>				Criterion : <u>B</u>	
Location	Polarity	Phase Angle	Number of Pulse	Pulse Voltage (KV)	Result
L-N	+	0°	5	1.0	A
	+	90°	5	1.0	A
	+	180°	5	1.0	A
	+	270°	5	1.0	A
	-	0°	5	1.0	A
	-	90°	5	1.0	A
	-	180°	5	1.0	A
L-PE	+	0°	5	2.0	A
	+	90°	5	2.0	A
	+	180°	5	2.0	A
	+	270°	5	2.0	A
	-	0°	5	2.0	A
	-	90°	5	2.0	A
	-	180°	5	2.0	A
N-PE	+	0°	5	2.0	A
	+	90°	5	2.0	A
	+	180°	5	2.0	A
	+	270°	5	2.0	A
	-	0°	5	2.0	A
	-	90°	5	2.0	A
	-	180°	5	2.0	A
-	270°	5	2.0	A	
Remark:				Test Equipment :	

13. INJECTED CURRENTS SUSCEPTIBILITY TEST

13.1. Block Diagram of Test Setup

13.1.1. Block Diagram of the EUT

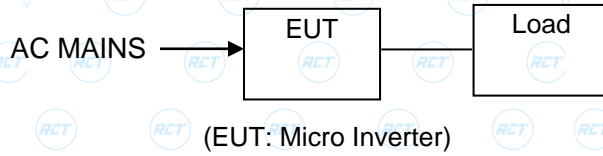

13.1.2. Block Diagram of Test Setup

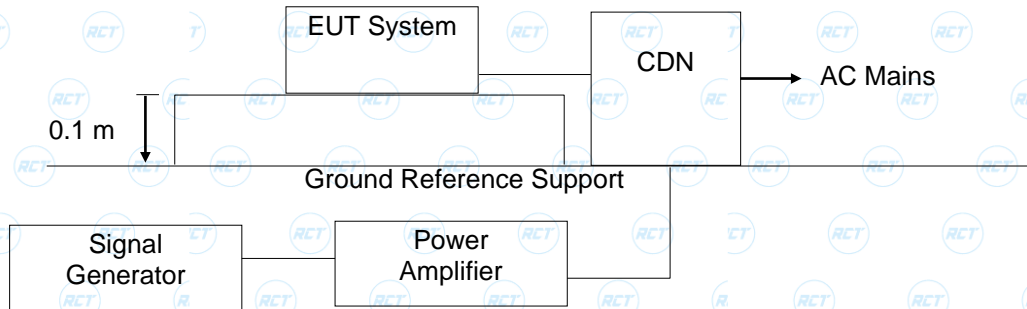

13.2. Test Standard

EN 61000-6-2:2005
(IEC 61000-4-6:2013, Severity Level: Level 3, 10V (rms), (0.15MHz ~ 80MHz))

13.3. Severity Levels and Performance Criterion

13.3.1. Severity level

Level	Field Strength V
1	1
2	3
3	10
X	Special

13.3.2. Performance Criterion: A

13.4. EUT Configuration

The configuration of EUT is listed in Section 4.4

13. 5.

Operating Condition of EUT

13. 5. 1.

Setup the EUT as shown in Section 13.1.

13. 5. 2.

Turn on the power of all equipments.

13. 5. 3.

Let the EUT work in test mode (ON) and measure it.

13. 6.

Test Procedure

1)

Set up the EUT, CDN and test generators as shown on Section 13.1.2.

2)

Let the EUT work in test mode and measure it.

3)

The EUT are placed on an insulating support 0.1m high above a ground reference plane. CDN (coupling and decoupling device) is placed on the ground plane about 0.3m from EUT. Cables between CDN and EUT are as short as possible, and their height above the ground reference plane shall be between 30 and 50 mm (where possible).

4)

The disturbance signal described below is injected to EUT through CDN.

5)

The EUT operates within its operational mode(s) under intended climatic conditions after power on.

6)

The frequency range is swept from 150KHz to 80MHz using 3V signal level, and with the disturbance signal 80% amplitude modulated with a 1KHz sine wave.

7)

The rate of sweep shall not exceed 1.5×10^{-3} decades/s. where the frequency is swept incrementally, the step size shall not exceed 1% of the start and thereafter 1% of the preceding frequency value.

8)

Recording the EUT operating situation during compliance testing and decide the EUT immunity criterion.

13. 7.

Test Results

PASS.

Please refer to the following page.

Injected Currents Susceptibility Test Results

Shenzhen RCT testing technology Co.,Ltd

Applicant : Dongguan kaideng Energy Technology Co., Ltd.				
EUT : Micro Inverter			Test Date : Aug 15, 2020	
M/N : WVC-1400			Temperature : 23°C	
Power Supply : AC 230V/50HZ			Humidity : 50%	
Test Mode : AC Charging & Discharging			Test Engineer : LZC	
Frequency Range (MHz)	Injected Position	Strength (Unmodulated)	Criterion	Result
0.15 ~ 80	AC Output	10V	A	A
Test Mode:				
Frequency Range (MHz)	Injected Position	Strength (Unmodulated)	Criterion	Result
Remark : 1. Modulation Signal:1KHz 80% AM Measurement Equipment : Simulator: CWS 500 (SWITZERLAND EMTEST) CDN : CDN-M2 (SWITZERLAND EMTEST) CDN-M3 (SWITZERLAND EMTEST)			Note:	

14. MAGNETIC FIELD SUSCEPTIBILITY TEST

14.1. Block Diagram of Test

14.1.1. Block diagram of test setup



(EUT: Micro Inverter)

14.1.2. Magnetic field test setup

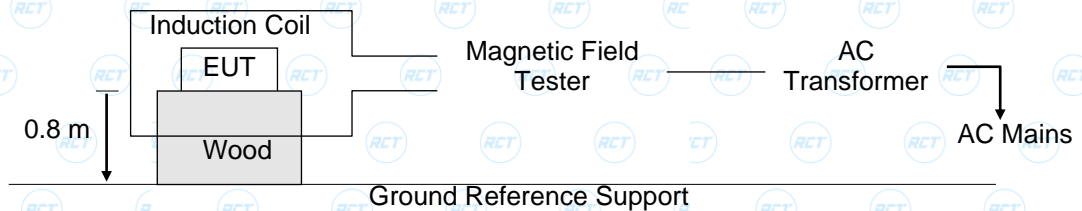

(EUT: Micro Inverter)

14.2. Test Standard

EN 61000-6-2:2005
(IEC 61000-4-8:2009, Severity Level: Level 4, 30A / m)

14.3. Severity Levels and Performance Criterion

14.3.1. Severity Levels

Level	Field Strength A/m
1	1
2	3
3	10
4	30
5	100
X	Special

14.3.2. Performance Criterion : A

14. 4.

EUT Configuration on Test

The configuration of the EUT is same as Section 4.4

14. 5.

Test Procedure

The EUT is placed in the middle of a induction coil (1*1m), under which is a 1*1*0.1m (high) table, this small table is also placed on a larger table, 0.8 m above the ground. The X, Y and Z polarization of the induction coil is set on test, so that each side of the EUT is affected by the magnetic field. Also can reach the same aim by change the position of the EUT.

14. 6.

Test Results

PASS.

Please refer to the following page.

Magnetic Field Immunity Test Result

Shenzhen RCT testing technology Co.,Ltd

Standard	IEC 61000-4-8 EN 61000-4-8	Result: <input checked="" type="checkbox"/> Pass / <input type="checkbox"/> Fail		
Input Voltage : <u>AC 230V/50HZ</u> Date of Test : <u>Aug 15, 2020</u> Test Engineer: <u>LZC</u> Ambient Condition : Temp : <u>22°C</u> Humid: <u>55%</u> Criterion : A				
Operation Mode : AC Charging & Discharging				
Test Level (A/M)	Testing Duration	Coil Orientation	Criterion	Result
30	5 mins	X	A	A
30	5 mins	Y	A	A
30	5 mins	Z	A	A
Operation Mode :				
Test Level (A/M)	Testing Duration	Coil Orientation	Criterion	Result
Test Equipment	Magnetic Field Test : HEAFELY MAG 100.1			
Note:				

15. VOLTAGE DIPS AND INTERRUPTIONS TEST

15.1. Block Diagram of Test Setup

15.1.1. Block Diagram of the EUT

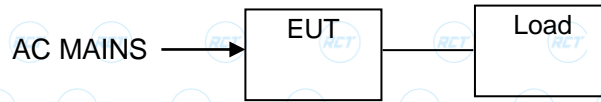

(EUT: Micro Inverter)

15.1.2. Dips Test Setup

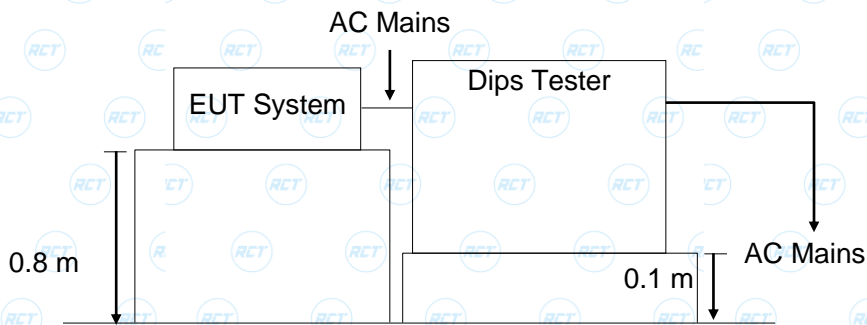

15.2. Test Standard

EN 61000-6-2:2005 (IEC 61000-4-11:2004)

15.3. Severity Levels and Performance Criterion

15.3.1. Severity level

Test Level %UT	Voltage dip and short interruptions %UT	Duration (in period)
0	100	1
40	60	10
70	30	25
0	100	250-

15.3.2. Performance Criterion: B&C

15.4. EUT Configuration

The configuration of EUT is listed in Section 4.4.

15. 5.

Operating Condition of EUT

15. 5. 1.

Setup the EUT as shown in Section 15.1.

15. 5. 2.

Turn on the power of all equipments.

15. 5. 3.

Let the EUT work in test mode (AC Charging & Discharging) and measure it.

15. 6.

Test Procedure

1)

Set up the EUT and test generator as shown on Section 15.1.2.

2)

The interruptions are introduced at selected phase angles with specified

duration.

3)

Record any degradation of performance.

15. 7.

Test Result

PASS.

Please refer to the following page.

Voltage Dips And Interruptions Test Results

Shenzhen RCT testing technology Co.,Ltd

Applicant : Dongguan kaideng Energy Technology Co., Ltd.		Test Date : Aug 15, 2020		
EUT : Micro Inverter		Temperature : 23°C		
M/N : WVC-1400		Humidity : 56%		
Power Supply : AC 230V/50HZ		Test Engineer : LZC		
Test Mode : AC Charging & Discharging				
Test Level % U _T	Voltage Dips & Short Interruptions % U _T	Duration (in periods)	Criterion A B C D	Result
0	100	250P	C	B
70	30	25P	C	A
40	60	10P	C	A
0	100	1P	B	A
Test Mode :				
Test Level % U _T	Voltage Dips & Short Interruptions % U _T	Duration (in periods)	Criterion A B C D	Result P=P ASS F=F AIL
Note:				

APPENDIX (PHOTOS OF EUT)

WVC-700



WVC-700

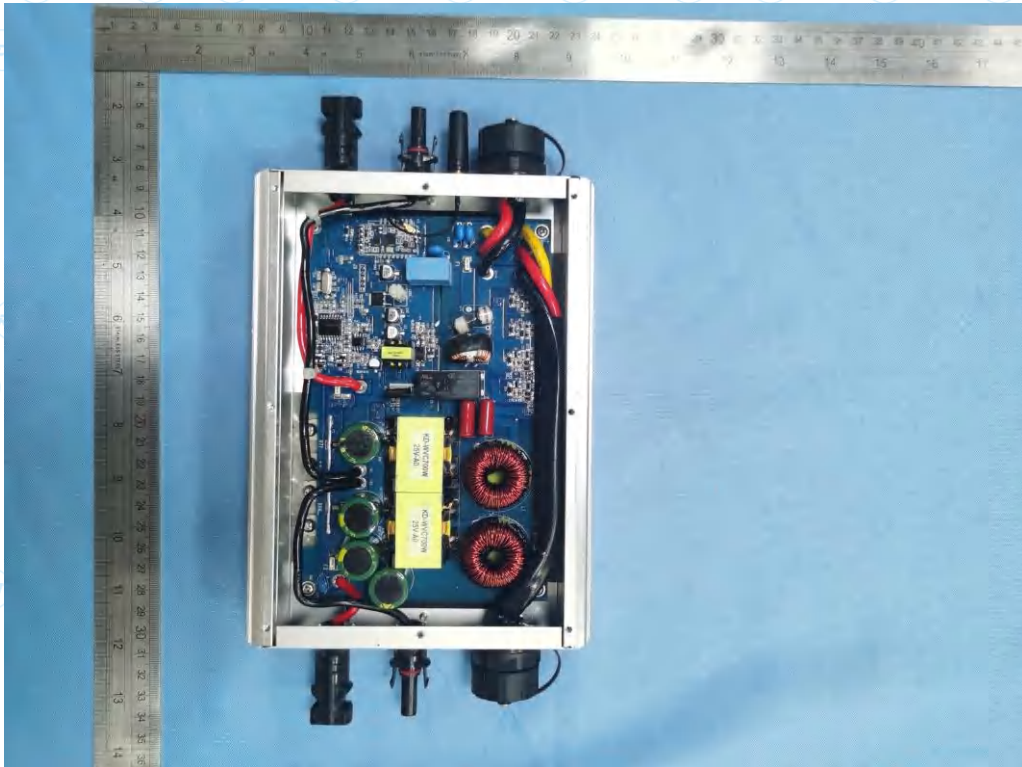
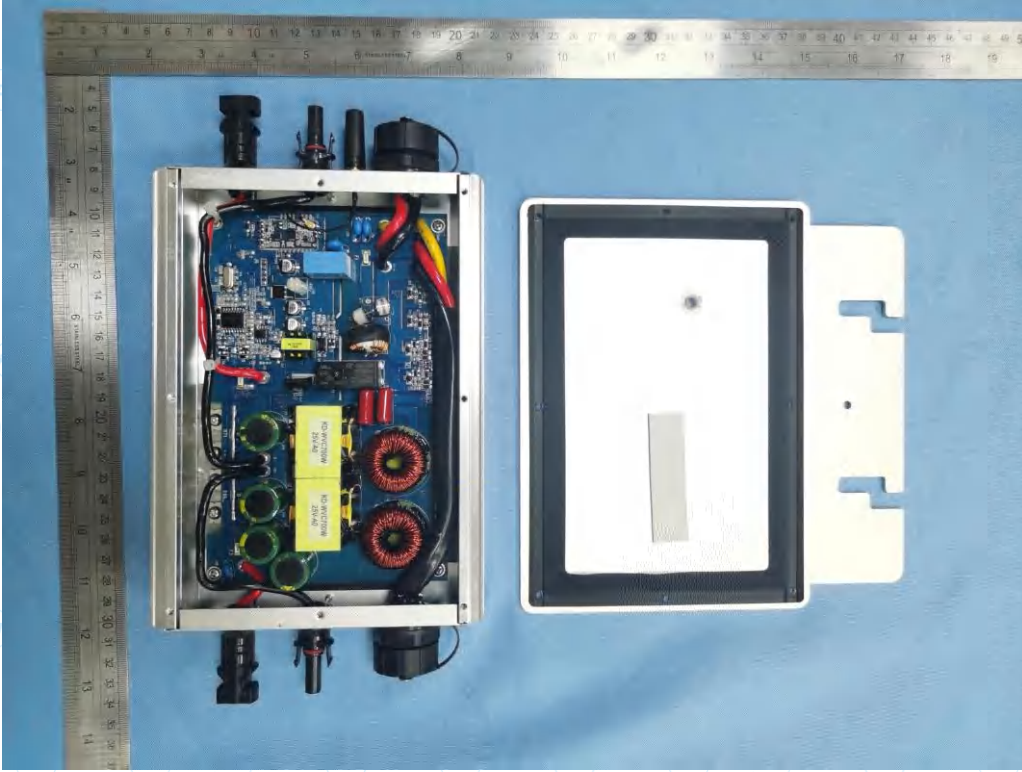

WVC-1400

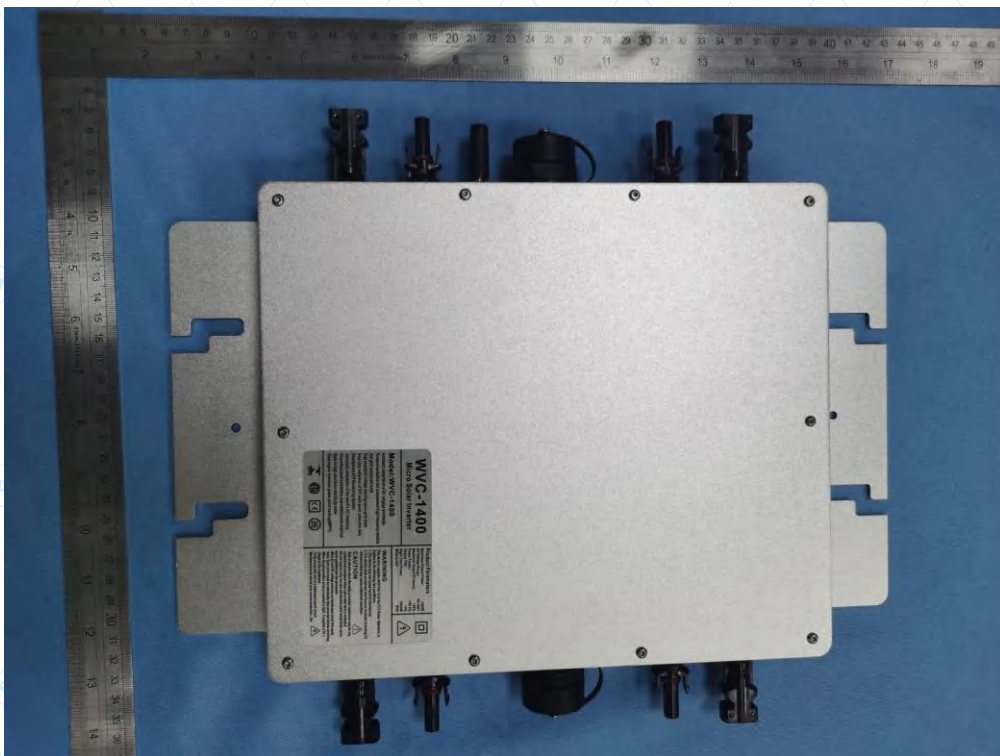

WVC-1400

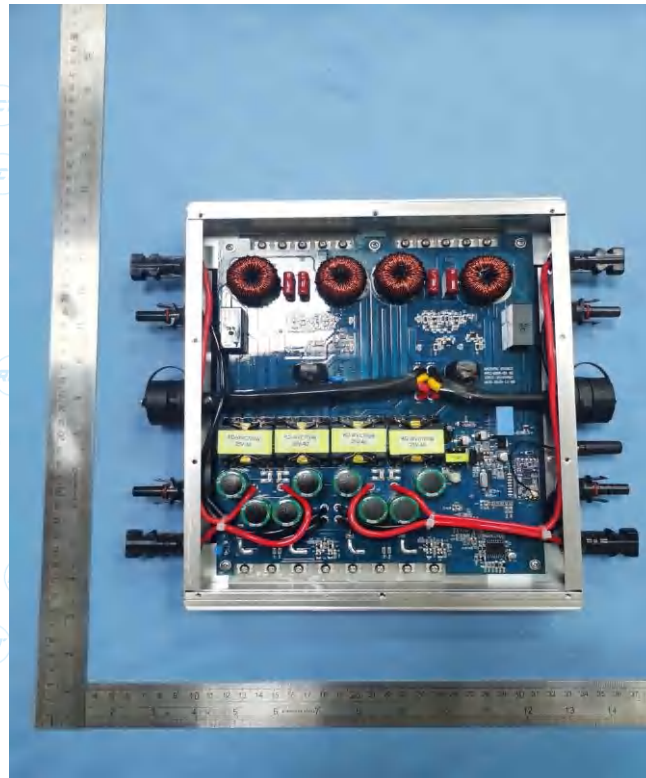
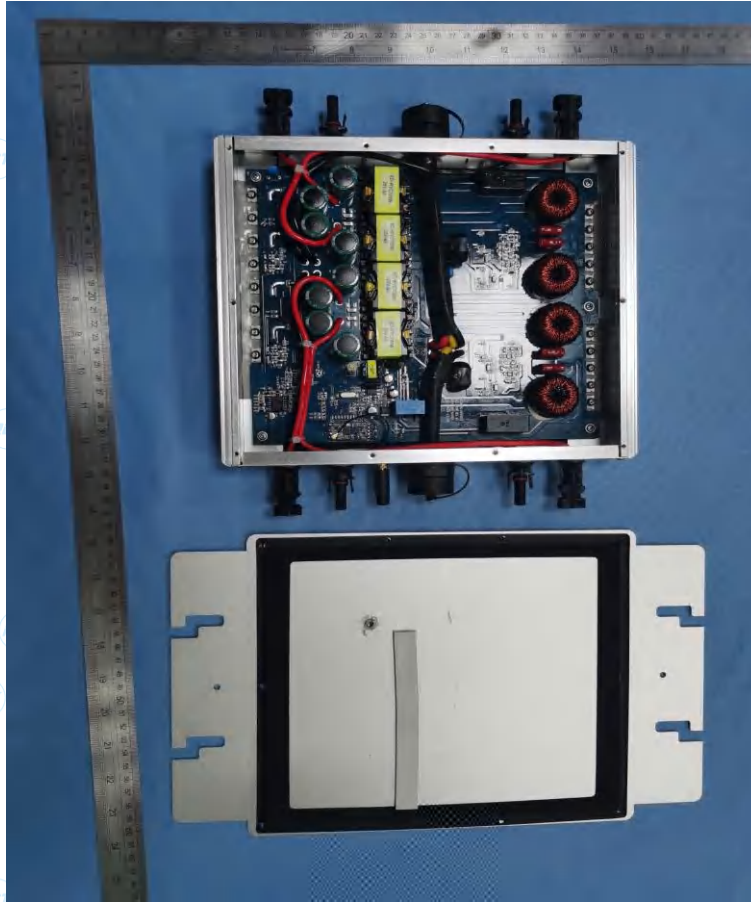

-----The End-----